

HELGA 6 COMPACT



SHORT DESCRIPTION

The integrated system of clothes distribution and collection It contains management software of the whole cycle of clothes circulation. Our product control and management covers all stages: distribution, collection, transportation from the customer, washing, potential repair, transportation to the customer and the loading of clothes ready to be taken into the distributing machines. Our machines recognize clothes by HF and UHF tags system or by means of barcode scanners.

BENEFITS

- Secure and availability of articles
- 24 hours a day, 7 days a week
- Reduced consumption
- CONTROLLED acquiring of single or packaged articles
- Availability of articles near the workplace
- Ability to set limits
- Employee supervision
- and many others...

PARAMETERS

Height	201cm / 79.13in
Width	99cm / 38.98in
Depth	89,2cm / 35.12in
Number of bins	216
Bins dimension	8 x 26 cm
Device weight	340 kg
Network connection	Ethernet connection, Wi-Fi, mobile internet (work possibility without internet connection)
Supply voltage	230 V
Power consumption	Standby - max. 37W; at max. load does not exceed 64W

BINS

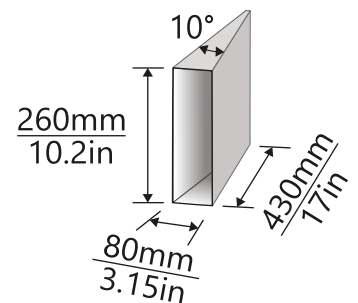

CONTACT

PSPG Polska Sp. z o.o.
227e Warszawska St.
05-092 Łomianki - Kielpin, Poland

+48 22 751 21 09,
+48 22 751 21 10
biuro@automatybhp.eu

www.automatybhp.eu